



Peachtree Distributing Inc.  
 3128 Nifda Dr SE  
 Atlanta, GA 30339  
 Ph: 800-333-5151 fax: 404-350-0781  
 www.pdiatlanta.com

# Kitchen Exhaust Air Cleaning Systems





Peachtree Distributing Inc.  
 3128 Nifda Dr SE  
 Atlanta, GA 30339  
 Ph: 800-333-5151 fax: 404-350-0781  
 www.pdiatlanta.com

# POLLUTION CONTROL UNITS

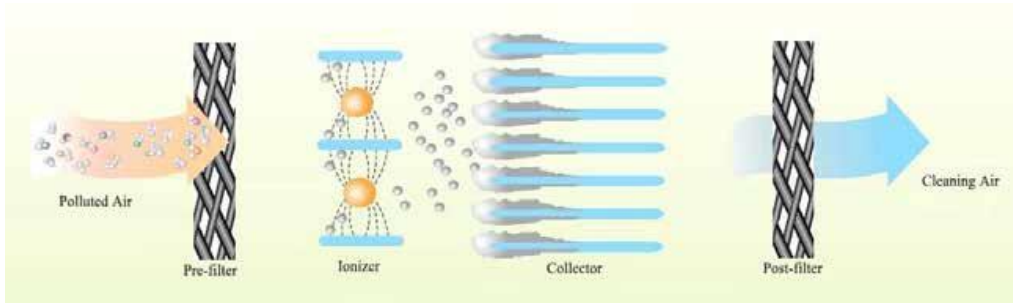

## AutoClean™

- + Self-wash cycle to eliminate filter replacement and electrostatic precipitator cell cleaning
- + Energy efficient units minimize electrical costs
- + Superior quality and construction virtually eliminates maintenance costs
- + Stackable customized modules provide design and installation flexibility for any size installations
- + Up to 99% efficient to ensure clean air
- + Optional carbon filters control odors

“ For the ultimate quality and features, choose the AutoClean™—a premier, multi-jet, programmable self-washing system. ”



## SMOKEMASTER® F72

- + Economical, non-wash system requires no plumbing
- + Available in galvanized or painted finish
- + Side access door for easy maintenance
- + Stackable customized modules provide design and installation flexibility for any size installations
- + Up to 99% efficient to ensure clean air

“ For an easy, economical solution, choose the F72 non-wash system. ”



Peachtree Distributing Inc.  
 3128 Nifda Dr SE  
 Atlanta, GA 30339  
 Ph: 800-333-5151 fax: 404-350-0781  
 www.pdiatlanta.com

# Pollution Control Units / Scrubbers

## AutoClean

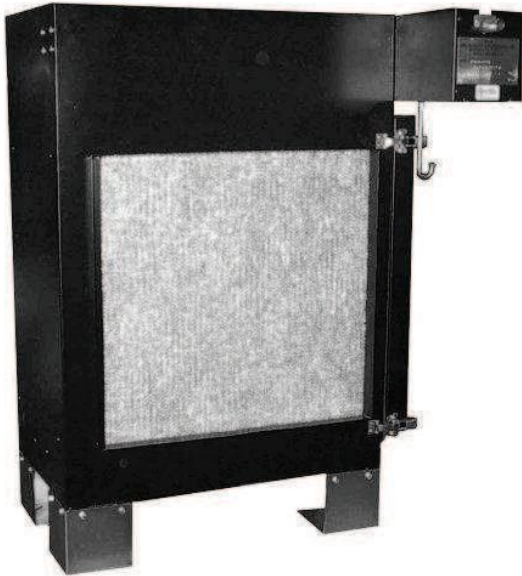

Self-wash cycle to eliminate filter replacement and electrostatic precipitator cell cleaning

Energy efficient units minimize electrical costs

Superior quality and construction virtually eliminate maintenance costs

Stackable customized modules provide design and installation flexibility for any size installations

Clean HVAC coils increase thermal efficiency for energy savings

Up to 99% efficient to ensure clean air

Optional carbon filters control odors

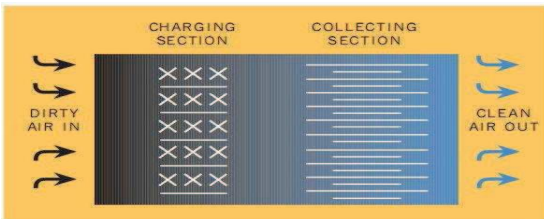

AUTOCLEAN 2000			AUTOCLEAN 4000			AUTOCLEAN 8000		
CFM	EFFICIENCY	S.P.	CFM	EFFICIENCY	S.P.	CFM	EFFICIENCY	S.P.
1000	99%	0.06"	2000	99%	0.06"	4000	99%	0.06"
1500	99%	0.12"	3000	99%	0.12"	6000	99%	0.12"
2000	95%	0.22"	4000	95%	0.22"	8000	95%	0.22"

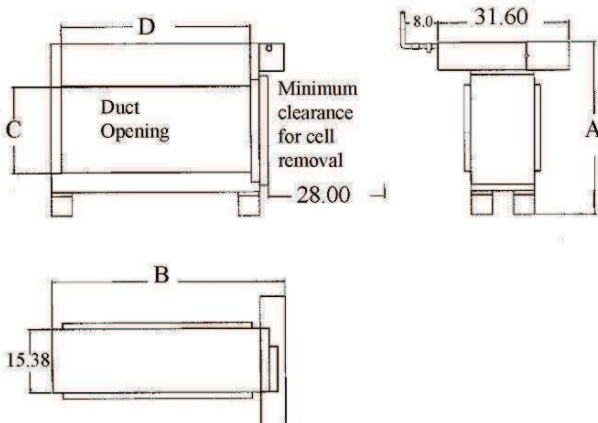

FAN MODEL	A	B	C	D	Weight
F61A	42	33	21	22	240
F61B	42	57	21	46	340
F61C	76	57	42	46	530

## F72 DUCTED ELECTRONIC AIR CLEANER

DESIGNED FOR DUCTED AIR CLEANING AND ODOR CONTROL

### APPLICATIONS

- Kitchen Exhaust Air Cleaning
- Industrial Air Cleaning

### STANDARD FEATURES

- Stacking Capacity to 48,000 CFM\*
- Hinged Access Door for Easy Cell Access
- Solid State, Dual Voltage Power Supply
- Industrial Electronic Cell



F72B SHOWN WITH ODOR MODULE MOUNTED ON A SKID

<b>WEIGHT:</b>	<b>Unit Installed*</b>	<b>Shipping*</b>
	F72A 595 lbs	700 lbs
	F72B 1020 lbs	1190 lbs
	* Weights are approximate	
<b>CABINET:</b>	16-Gauge Galvanized Steel	
<b>POWER INPUT:</b>	F72A: 100-120 VAC, 50/60 Hz F72B: 200-240 VAC, 50/60 Hz 50 Nominal Watts, 100 Maximum	
<b>POWER SUPPLY:</b>	Solid state, self-regulating dual voltage output. Nominal output voltages are 9400 VDC on the ionizer and 4700 VDC on the collector. Power supply momentarily turns off during over-current situation	
<b>CELL SPECIFICATION:</b>	Dimensions: 24 1/4" L x 10 3/4"W x 24 1/8"H Weight: 60 lbs per cell Collection Area: 240 Ft <sup>2</sup> Voltage Gradient: 20,000 volts per in. Min. F72A: One Cell F72B: Two Cells	
<b>PRE/POST FILTERS:</b>	1" multi-layer aluminum mesh	
<b>ODOR MODULE:</b>	F72A: 144 lbs of activated carbon F72B: 288 lbs of activated carbon	
<b>DIAGNOSTICS:</b>	System indicator light and test button	
<b>UPGRADES:</b>	Welded cabinet Half cells for easier maintenance Drain and plug Motor/blower package	

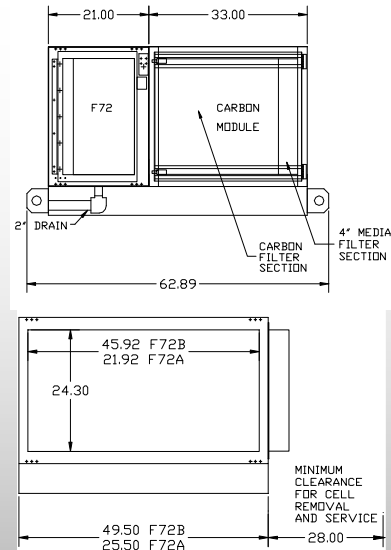

### EFFICIENCIES:

F72A CFM	F72B CFM	EFFICIENCY
1000	2000	99%
1500	3000	99%
2000	4000	95%
2500	5000	90%
3000	6000	80%

ETL listed to UL-867 and UL-710

\*Contact Peachtree Distributing regarding stacking capacity beyond 48,000 CMF. PDI also provides Loren Cook air movers, which are sized to accommodate the required air flow in the ductwork system.



Peachtree Distributing Inc.  
3128 Nifda Dr SE  
Atlanta, GA 30339  
Ph: 800-333-5151 fax: 404-350-0781  
www.pdiatlanta.com





Peachtree Distributing Inc.  
3128 Nifida Dr SE  
Atlanta, GA 30339  
Ph: 800-333-5151 fax: 404-350-0781  
www.pdiatlanta.com

## COMPARED TO OTHER SYSTEMS

### Key Benefits of the AutoClean Series Systems:

- Efficiency of the wash system: AutoClean units have a wash arm that rotates and traverses for excellent coverage of the cells, pre filters, and post filters. This provides a much higher cleaning efficiency compare to competing models. **(Smog-Hog/Trion)**
- Lower cost of ownership due to the washable filters (cells), versus the expensive replacement filters found in media type filtration systems. **(Captive Aire)**
- Available in modules or complete: If assembling on site, you can purchase only the components that you need; as well as turnkey systems. **(Smog-Hog/Trion, Captive Aire)**
- Green product: Uses less wash water than competing auto wash systems. AutoClean doesn't doesn't fill landfills with disposable filters like media type systems. **(Captive Aire)**
- The self-washing feature reduces or eliminates the necessity for expensive cell cleaning services. Based on the cost savings versus manual clean units, the AutoClean pays for itself over time. **(Captive Aire)**

### Key Benefits of the F-72 Series Systems:

- Very small footprint: allows unit to be placed in areas where competing models will not fit **(Smog-Hog/Trion, Captive Aire)**
- Lower cost of ownership due to the washable filters (cells), versus the expensive replacement filters found in media type filtration systems. **(Captive Aire)**
- Available in modules or complete: If assembling on site, you can purchase only the components that you need; as well as turnkey systems. **(Smog-Hog/Trion, Captive Aire)**
- Green product: Doesn't fill landfills with disposable filters like media type systems. **(Captive Aire)**
- Entry level type system. Very affordable. **(Smog-Hog/Trion, Captive Aire)**