



**SPECIFIER ITEM NO.** \_\_\_\_\_

**CHG PART NO.** \_\_\_\_\_



*Encore*



Encore® Deck Mount Pre-Rinse Assembly with Wall Bracket

## KN56-1000-BR

### ENGINEERING SPECIFICATION:

- Polished chrome plated cast brass
- Deck Mount Faucet w/ 4" Adjustable Centers
- One Piece Supply Inlet Couplings
- Mounting Hardware Included
- 1/4 Turn Compression Valves w/In-line Check Valves
- Lever Handles w/SANIGUARD® treated
- S/S Flex Hose w/Santoprene Reinforced Hose and Strain Relief

### TECHNICAL/PERFORMANCE SPECIFICATIONS:

- Commercial Specification Grade
- 1/2 NPS Male Inlets
- Gaskets and Seals Rated Commercial Hot 180°F
- Operating Temperature: 40 - 180°F
- Operating Pressure: 15 - 125psi
- Handle and Grip: SANIGUARD® treated

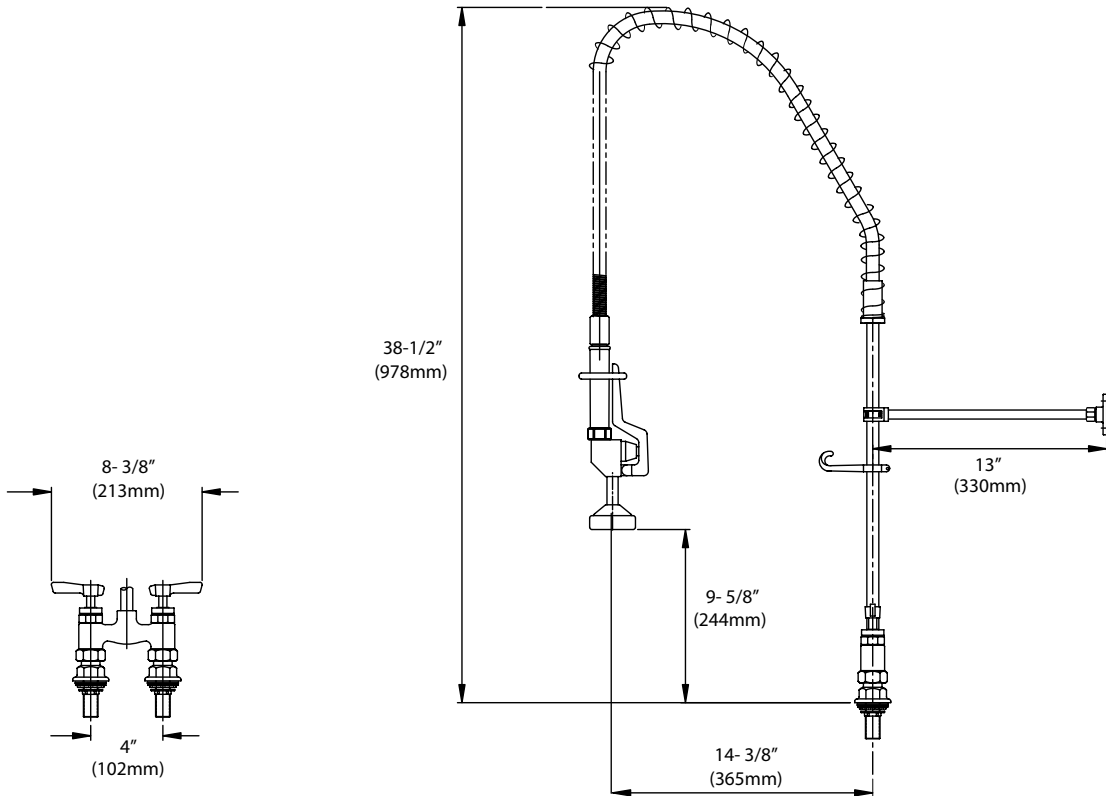

Dimensions shown in inches (mm) are for reference only and are subject to change.

## MODEL NO. KN56-1000-BR

### OPTIONS:

#### Handles

- K50-0001 4" Wrist Blade Handles
- K50-0001-6 6" Wrist Blade Handles
- K50-X011 Cross Handle Replacement Kit
- K50-X117 Chrome Plated Designer Handles

#### Valves

- KN50-Y006-CCV Cold 1/4 Turn Ceramic valve with Inline Check Valves
- KN50-Y007-CCV Hot 1/4 Turn Ceramic Valve with Inline Check Valves

#### Add-On Faucets

- KN55-7006 With 6"(152mm) Swing Spout
- KN55-7008 With 8"(203mm) Swing Spout
- KN55-7010 With 10"(254mm) Swing Spout
- KN55-7012 With 12"(305mm) Swing Spout
- KN55-7014 With 14"(356mm) Swing Spout
- KN55-7016 With 16"(406mm) Swing Spout

#### Vacuum Breakers

- K50-X139 Top of Riser Atmospheric Vacuum Breaker
- K50-X139-B Bottom of Riser Atmospheric Vacuum Breaker
- K50-X196 In-Line Hose Application