



**SPECIFIER ITEM NO.** \_\_\_\_\_

**CHG PART NO.** \_\_\_\_\_



## Encore® Wall Mount Utility Spray Assembly **KN53-2000-VB**

### **ENGINEERING SPECIFICATION:**

Polished Chrome Plated Brass  
Wall mount faucet w/ adjustable 8" Inlet Centers  
One piece supply coupling  
1/4 Turn Commercial Valve w/ Check Valve  
Lever Handle w/ SANIGUARD® treatment  
Stainless Steel Strain Relief – Patented  
S/S Flex hose w/Santoprene reinforced inner hose  
O-Ring Seals – Patented  
Hold open ring and hose wall hook included

### **TECHNICAL/PERFORMANCE SPECIFICATIONS:**

Commercial Specification Grade  
Gaskets and Seals Rated Compression Hot 180°F  
1/2" NPT Female Inlets  
Operating Temperature: 40 - 180°F  
Operating Pressure: 15 - 125psi  
Handle and Grip: SANIGUARD® Treatment

*Encore*

**SANIGUARD**  
THE POWER OF SILVER

COMPLIES WITH:  
ASME A112.18.1-2005  
CSA B125.1-05  
NSF/ANSI 61 / 9  
Uniform Plumbing Code



### **OPTIONS:**

#### *Handles*

- K50-0001 4" WRIST BLADE HANDLES
- K50-X011 COSS HANDLE REPLACEMENT KIT
- K50-X117 CHROME PLATED DESIGNER HANDLES

#### *VALVES*

- KN50-Y006-CCV COLD 1/4 TURN CERAMIC VALVE WITH INLINE CHECK VALVES
- KN50-Y007-CCV HOT 1/4 TURN CERAMIC VALVE WITH INLINE CHECK VALVES

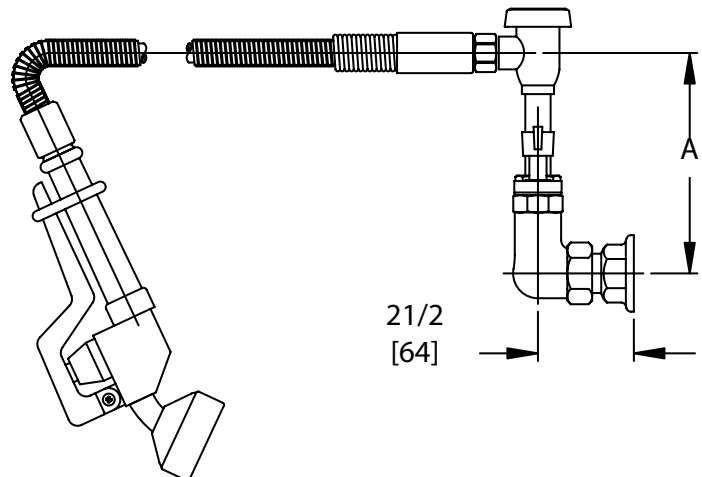
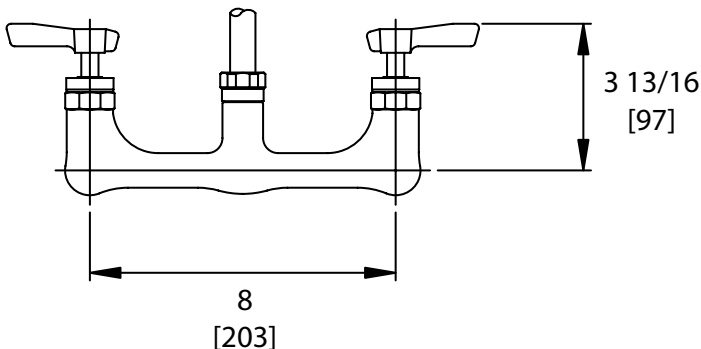
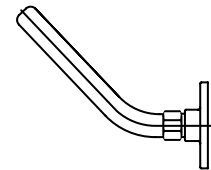

*Dimensions shown in inches (mm) are for reference only and are subject to change.*