



AutoClean **In-Duct Self Cleaning** **Electronic Air Cleaner**

The new AutoClean from Air Quality Engineering, Inc., is a self-washing in-duct electronic air cleaning system. The AutoClean will effectively remove a broad range of contaminants including coolant mist, dust, soot, pollen, tobacco, and cooking smoke from the air. One, Two or Four electronic cells, operated by high voltage power supplies remove airborne contaminants at efficiencies as high as 99 percent and at rates starting at 1000 cfm. Dynamic Wash system is the state-of-the-art in maintenance free air cleaning.

The wash cycle for the electronic cell is controlled by the built in Programmable Logic Controller. Wash cycle time can be easily selected on the touch screen PLC for each day of the week. Also the wash cycle may be manually started through touch screen of PLC.

The duration of wash, rinse and dry time can be changed on PLC menu.

PLC has two independent advanced menu options:

1. You can have fan "on" or "off" during drying.
2. The unit can go to "sleep" mode after wash.

Optional HMI (Human Machine Interface) screen could be installed remotely in convenient location.

HMI screen could be connected by Ethernet cable to one unit's PLC or to multiple units through Ethernet switch. On HMI screen user can select the unit to modify the settings. Max number of units per HMI is eight. All settings used in the unit PLC are accessible (you can change them) from HMI screen.

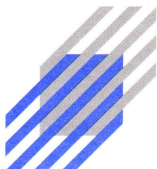

AIR QUALITY
ENGINEERING

7140 Northland Drive North, Brooklyn Park, MN 55428-1520 USA

FAX: (763) 531-9900 **EMAIL:** info@air-quality-eng.com **WEB SITE:** www.air-quality-eng.com

TOLL FREE: 1-800-328-0787

Air Quality Engineering Inc., has a policy of continuing product improvement and reserves the right to make changes in design and specification without notice.

Before you get started please review the following:

Purchase Date: _____

Serial Number: _____

Customer Technical Support:

To contact Air Quality Engineering use:

Mail: Air Quality Engineering
7140 Northland Drive N.
Brooklyn Park, MN 55428
USA

Phone: 1.800.328.0787
763.531.9823

Fax: 763.531.9900

e-mail: info@air-quality-eng.com

web: www.air-quality-eng.com

Copyright

Air Quality Engineering, Inc. copyrights this manual with all rights reserved. Under the copyright laws, this manual may not be reproduced in any form, in whole or in part, without the prior written consent of Air Quality Engineering, Inc.

© 2018

Disclaimer

All statements, technical information and recommendations in this manual or related documents are believed reliable, but the accuracy and completeness thereof are not guaranteed or warranted, and they are not intended to be, nor should they be understood to be representation or warranties concerning the products described.

Specifications are subject to change without notice.

TABLE OF CONTENTS

	PAGE
HOW AIRBORNE CONTAMINATION IS REMOVED	1
DIMENSIONS	2
SPECIFICATIONS	6
PLANNING THE INSTALLATION	7
ASSEMBLY & INSTALLATION	10
CHECKOUT	15
MAINTENANCE	16
TROUBLESHOOTING	19
PLC INSTRUCTIONS	21
WARRANTY	26

HOW AIRBORNE CONTAMINATION IS REMOVED

A process called “Electrostatic Precipitation” traps airborne contaminants. The fan draws particulate laden air successively through the prefilter, the cell ionizing section and the cell collector section. The ionizing section imparts an electrical charge to the individual particles that are then drawn by electrostatic forces to the oppositely charged collector plates.

The electronic cells must be washed periodically to maintain efficient performance.

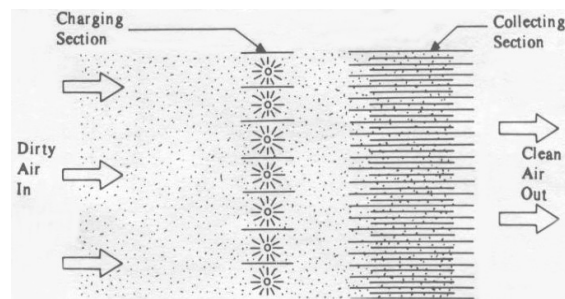

DIMENSIONS

AutoClean 2000

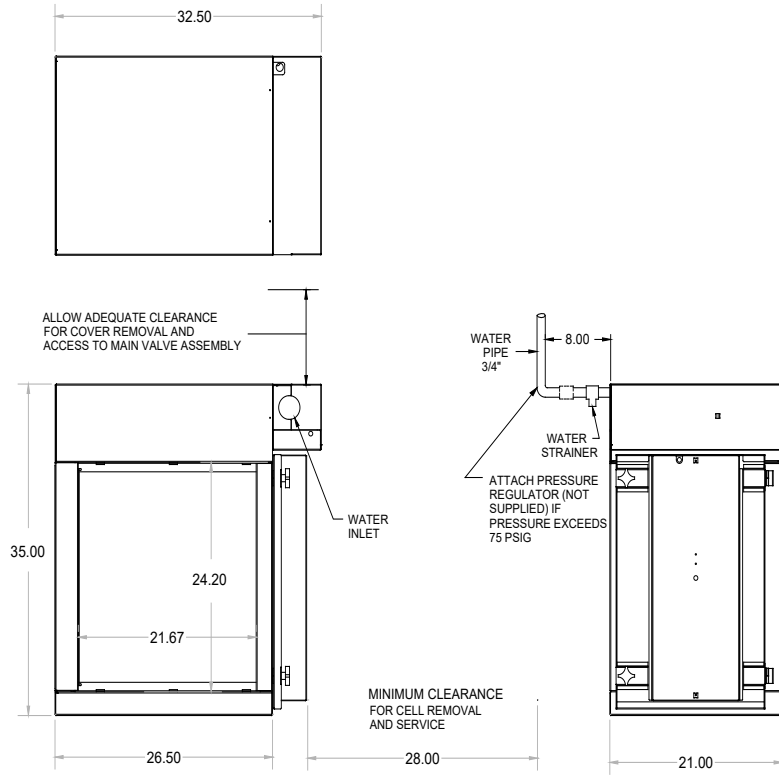

AutoClean 4000

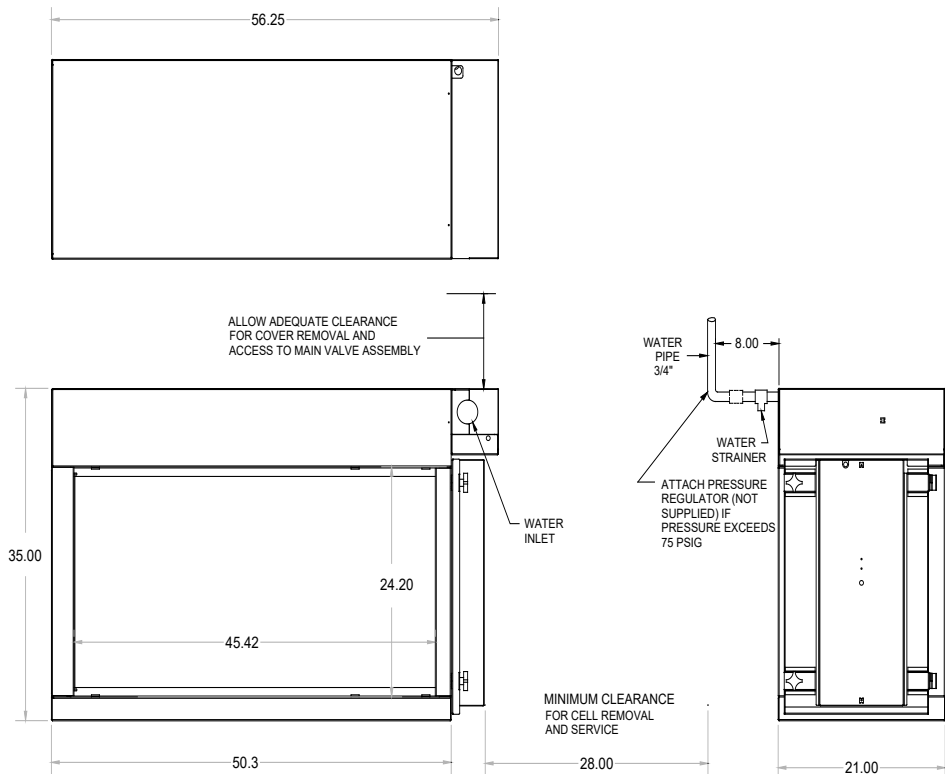

AutoClean 8000 dimensions

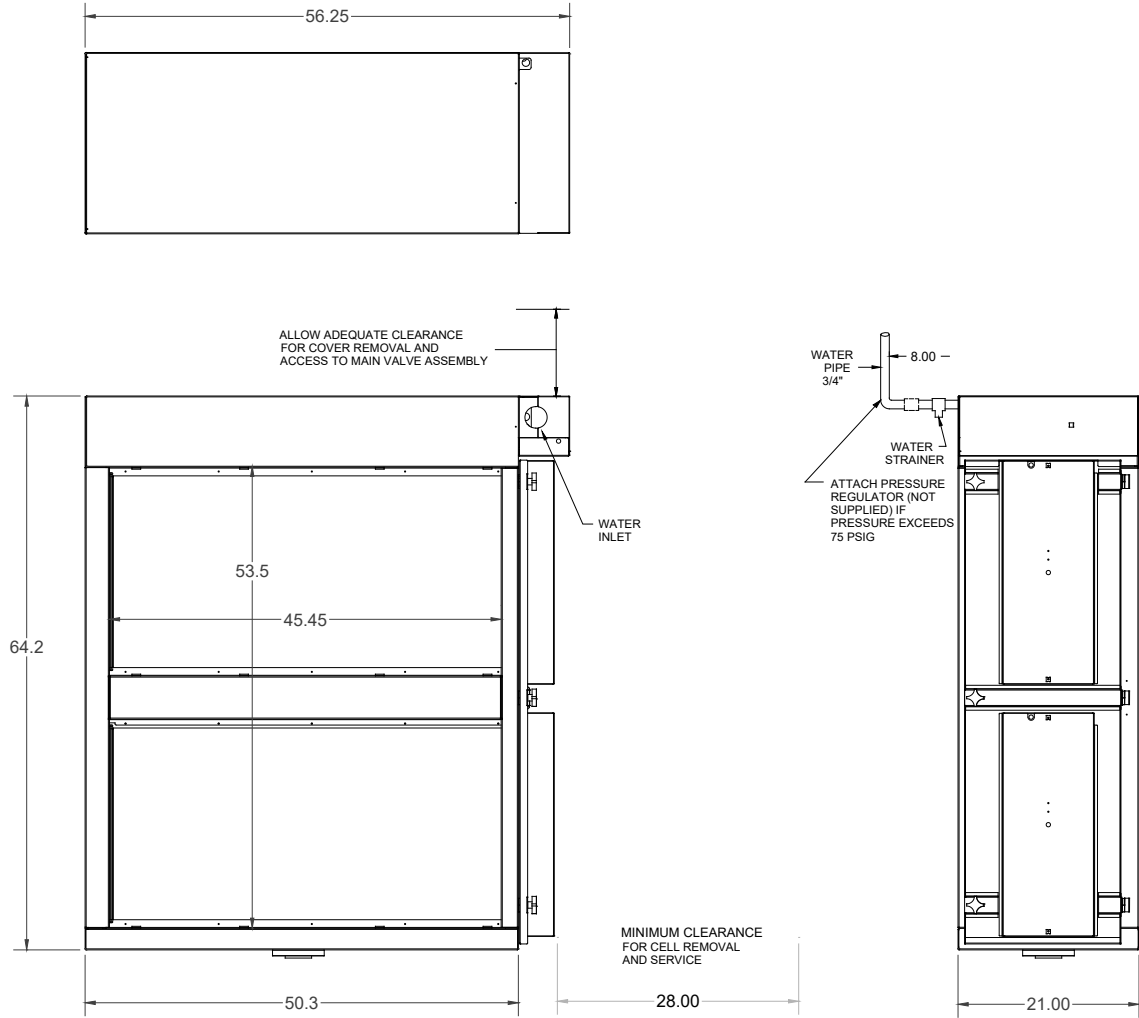

METRIC CONVERSION	FORMULA
Ins. to mm	Ins. x 25.4
Lbs. to kgs.	Lbs. x .455
Ins. w.g. to kPa	Ins. w.g. x .2488
CFM to m ³ /h	CFM x 1.6992
Ft ² to m ²	Ft ² x .0929

	SHIPPING WEIGHT		INSTALLED WEIGHT	
	Lb.	Kg.	Lb.	Kg.
AutoClean 2000	300	136	255	116
AutoClean 4000	390	181	355	161
AutoClean 8000	640	290	570	259

SPECIFICATIONS

- IMPORTANT -

THE SPECIFICATIONS GIVEN IN THIS PUBLICATION DO NOT INCLUDE NORMAL MANUFACTURING TOLERANCES. THEREFORE, THIS UNIT MAY NOT MATCH THE LISTED SPECIFICATIONS EXACTLY. ALSO, THIS PRODUCT IS TESTED AND CALIBRATED UNDER CLOSELY CONTROLLED CONDITIONS AND SOME MINOR DIFFERENCES IN PERFORMANCE CAN BE EXPECTED IF THOSE CONDITIONS ARE CHANGED.

SPECIFICATIONS

Cabinet: 16 and 14 gauges welded steel cabinet with a powder coat finish.

Instrumentation: Indicator Light – Light indicates that the collector cells are energized properly.

Electrical Rating: AutoClean In-place Wash Electronic Air Cleaner-120V/240V, 60 Hz; or 220-240V, 50 Hz

Ambient Temperature Rating: Airflow through cells: 125°F [52°C] max., 40°F [5°C] min.

Power Ratings:
115V, 1.5Amps; 230V, 0.75 Amps

Pre/post Filter:
AC2000: two 24" x 24" x 1" Heavy duty aluminum mesh filters.
AC4000: four 24" x 24" x 1" Heavy duty aluminum mesh filters.
AC8000: eight 24" x 24" x 1" Heavy duty aluminum mesh filters.

Primary Filter Options:
AC2000: one 24" x 24" x 10.75" or two 24" x 12" x 10.75" Electronic cells
AC4000: two 24" x 24" x 10.75" or four 24" x 12" x 10.75" Electronic cells
AC8000: four 24" x 24" x 10.75" or eight 24" x 12" x 10.75" Electronic cells

Optional Carbon Filter:
Custom carbon modules available

Optional Blower Module:
Custom blower modules available

Optional Enclosure and Mounting:
Optional outdoor weather enclosure and mounting skid available

Air Quality Engineering, Inc. has a policy of continuing product improvement and reserves the right to make changes in design and specifications without notice.

PLANNING THE INSTALLATION

INTRODUCTION

Clean air is the subject of numerous laws and regulations. Typical requirements in the United States are those put out by the Occupational Safety and Health Administration (OSHA). Private groups, such as the American Society of Heating, Refrigeration and Air Conditioning Engineers (ASHRAE), have also published numerous recommendations.

Normally, clean air is defined in regulations and recommendations as air having a limited amount of contaminant in it, commonly expressed as parts per million or milligrams per cubic meter. Approved counteractions are intended to lower or eliminate the amount of contaminants in the air. One of the more common methods of achieving this goal is through the use of air cleaners.

AIR CLEANER SIZING

The AutoClean air cleaner is usually sized according to the capacity of the air handling system and the desired efficiency. See Fig. 3.

The ASHRAE Standard 62-81, Natural and Mechanical Ventilation, gives recommended quantities of ventilation air in terms of 100 percent

outdoor air. The Standard recommends as much as 50 CFM per person ventilation air where people are smoking, such as in a cocktail lounge. These recommended outdoor air quantities may be reduced if air cleaning is provided. However, the standard recommends that "in no case shall the outdoor air quality be less than five CFM per person."

The reduction in outside ventilation air required represents the potential for savings through the use of clean recirculated air. This potential for savings can be achieved by a system that reduces particulate and gaseous contaminants to within the ASHRAE recommended limits.

The AutoClean helps to provide this clean, recirculated air by removing particulate contamination (visible smoke). The reduction in outdoor air used, of course, means a reduction in the amount of heating or cooling required. This reduces both operating cost and equipment wear.

Remember that the air cleaner must meet the needs of the user. You are encouraged to use your experience and judgment in the application of this data keeping in mind local codes and minimum air requirements.

Airflow recommendation with pressure drop and efficiency rating:

F 61 A		F 61 B		F 61 C		Efficiency (Percent)	Water Pressure Drop	
cfm	M ³ /hr	cfm	M ³ /hr	cfm	M ³ /hr		In.	KPa
1000	1699	2000	3398	4000	6896	99	0.06	0.015
1500	2548	3000	5097	6000	10,194	99	0.12	0.030
2000	3398	4000	6796	8000	13,592	95	0.22	0.055
2500	4248	5000	8495	10,000	16,990	90	0.33	0.083
3000	5296	6000	10,194	12,000	20,388	80	0.49	0.122

Efficiency ratings based on National Bureau of Standards Dust Spot Method and American Society of Heating, Refrigerating and Air-Conditioning Engineers Standard 52-76, using atmospheric dust.

FIGURE 3 – AutoClean ELECTRONIC AIR CLEANER CAPACITY AND EFFICIENCY

COMMERCIAL APPLICATIONS

When deciding on the number of air cleaners required for applications such as a restaurant, bowling alley, store, bar or lounge, several conditions must be considered. They are:

1. Air to be cleaned of dust, tobacco smoke, greases, etc. These conditions may require a higher efficiency in the electronic air cleaner installation.
2. Capacity cubic feet per minute (cfm) of equipment and system.
3. Method of calculation-must be forced air, distributed evenly to all parts of the controlled area with the required air changes per hour.
4. Maximum number and average number of people that will occupy controlled area.

- The percent operating efficiency required of the electronic air cleaner. The AutoClean efficiency should be from 85 to 95 percent depending on the application and purpose. See Efficiency Chart, Fig. 3.

Contact an Air Quality Engineering Representative for assistance on commercial sizing.

INDUSTRIAL APPLICATIONS

Sizing is determining how many air cleaning units are required to maintain a desired level of air quality. The process to sizing an industrial application involves roughly figuring the number of air cleaners needed and then modifying the figures according to the specific characteristics of each application.

For ambient air cleaning, the estimated number of electronic air cleaners may be determined by the relationship of air volume to the needed air changes per hour.

An alternative method for calculating the estimated number of electronic air cleaners can be used if it is possible to measure the generation rate of the contaminants and the allowable level of contamination.

To use either method of calculation, contact an Air Quality Engineering Representative for assistance on industrial sizing.

Regardless of the method used to calculate the number of units needed to produce clean air, the physical conditions of the space to be cleaned may either limit this number or demand that more units be installed. For ambient air cleaning, it is important to establish a uniform airflow pattern throughout the entire space. Limitations to the calculated sizing may be a lack of space for mounting areas or the number of units may interrupt normal building operation; that is, a unit cannot be mounted where an overhead crane will smash into it or where stand mountings seriously interrupt building traffic patterns. The number of units required by air volume and air changes per hour might need to be increased when the shape of a structure is such capturing and air distribution is not possible according to the sizing calculations that effective.

LOCATION AND POSITION

Because air-handling systems vary greatly in arrangement and style, factors such as location, air distribution, transitions, etc., require careful consideration.

The AutoClean cabinet must be mounted in a horizontal duct in an upright position with the washing manifold above the electronic cells. Locate the cabinet in the return air duct so that the face of the electronic cell is at right angles to the airstream.

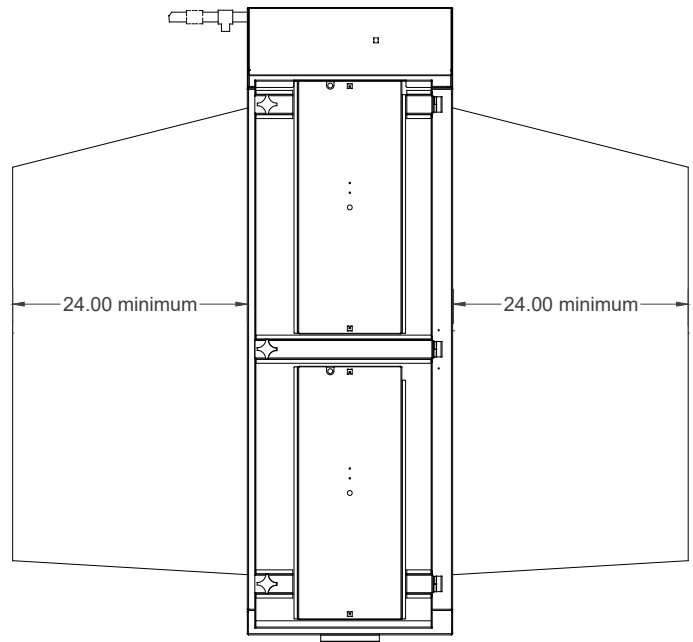

FIGURE 4 – TYPICAL INSTALLATION

CENTRAL DETERGENT SYSTEM FOR MULTIPLE AIR CLEANERS

When the installation includes two, three or four AutoClean air cleaners, they can be positioned so that the wash detergent can be pumped from a centrally located tank. Maximum horizontal distance from air cleaner cabinet to detergent tank is 15 ft., maximum vertical distance is 7 ft.

TRANSITIONS

When adapting the duct to fit the air cleaner, use gradual transitions in duct size to prevent turbulence and to increase efficiency.

Duct transitions should not exceed 20 degrees (about 4" per lineal foot) on each side of a fitting.

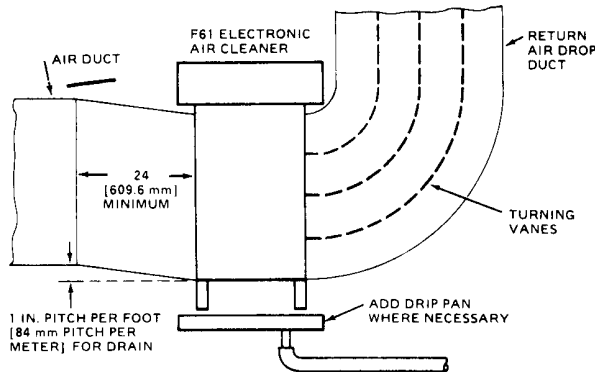

Fig. 5: TYPICAL INSTALLATION WITH TURNING VANES IN AIR DUCT

OUTDOOR AIR

When outdoor air is added to the return air duct, sufficient heat must be added to maintain a uniform a temperature between 50°F and 125°F. Two methods are recommended:

1. **Baffles.** Mixing baffles should be used to mix the outdoor air and the return air before it enters the air cleaner.
2. **Preheat Coil.** If large amounts of outdoor air are used, it must be heated. An appropriate control system should be used to control the heating element (electric strip heater, steam coil, etc.).

Outdoor air intakes should be protected to prevent the introduction of unnecessary contaminants.

Depending on the installation, it may be necessary to incorporate some or all of the precautions mentioned below:

1. Outdoor air intakes should be hooded or louvered to provide adequate protection from rain and snow. The type of hood used will depend upon the installation and expected weather.
2. Outdoor air intakes should always be equipped with a "bird screen."
3. At times it may be desirable to install a prefilter ahead of the electronic air cleaner. This is done to remove contaminants that could be harmful to the air cleaner or might cause excessively fast dirt buildup or arcing in the electronic cell.

WATER DAMAGE PROTECTION

If the installation is going to be overhead, provide a sheet metal pan with a drain under the entire AutoClean cabinet. This is important in case of water leaks in the ductwork or in the case of a plugged drain.

Make certain a drainpipe of sufficient size and slope is roughed-in to the bottom of the air cleaner cabinet at the planned location.

AIR CONDITIONING

Make certain the cooling coil is installed **downstream** from the air cleaner cabinet to prevent condensation and chilled air (cooler than 40°F [5°C]) from entering the cell.

HUMIDIFIERS

Location of the system humidifier is important to the operation of the air cleaner.

An evaporative type humidifier may be installed between the furnace warm air duct and the return air duct without affecting the electronic air cleaner.

ASSEMBLY & INSTALLATION

- IMPORTANT -

This section includes information for the sheet metal, plumbing and electrical installation. Make certain each person involved with the installation is aware of the appropriate subsections in the manual.

- CAUTION -

Do NOT connect the power source until after the air cleaner is completely assembled.

If the air cleaner must be turned on for an electrical check, be extremely careful in avoiding electrical shock. Also, take care to avoid the air cleaner's moving parts.

UNPACKING

Remove all shipping cardboard and banding. Be sure to inspect the packaging material before discarding it.

Depending on the placement of the air cleaner (roof top for example) a lifting crane might be necessary. Make sure that the air cleaner and components are properly supported before lifting.

WHEN INSTALLING THIS PRODUCT

1. Read these instructions carefully. Failure to follow them could damage the product or cause a hazardous condition.
2. After installation is complete, check out product operation as provided in these instructions.

If placing on a rooftop make sure there is proper clearance between the rooftop and the air cleaner. This can be achieved with mounting beams or by keeping the lifting supports in place.

All components are individually packaged and shipped in one large box. Before proceeding, carefully open each carton and visually check for possible damage to the air cleaner components.

1. Cabinet with electronic cells inside and control box mounted.
2. Drain connection.
3. Water strainer.
4. Accessories, if ordered.

If the air cleaner is installed in a location where water damage is possible, install a sheet metal pan with drain under the air cleaner cabinet and sloped ductwork.

SHEET METAL INSTALLATION

Air Distribution and Ductwork

The AutoClean operates most efficiently when all system air is delivered across the electronic cell at a uniform velocity. Turning vanes should be added to any return airdrop upstream from the air cleaner. See Fig. 5.

Gradual transitions to the AutoClean cabinet are recommended in all ductwork larger or smaller than the cabinet opening. If transitions are used, they should not exceed 20 degrees (4" rise per linear ft.

Install the Air Cleaner

Mount the AutoClean Air Cleaner as Follows:

1. Fabricate and install the necessary vanes and transitions.
2. Set the cabinet in position.
 - a. If hanging brackets are used, make certain the brackets are strong enough to hold the cabinet and the cabinet is attached firmly to the brackets.
 - b. Leave clearance above the control box to remove the cover and apply a wrench to the water strainer.
3. Ductwork preparation
 - a. Drill clearance holes for sheet metal screws in the cabinet which will not cause leaking. Remember that the ductwork must be water-tight near the cabinet.
 - b. Fasten the duct to the cabinet opening with sheet metal screws.
 - c. Use caulking compound (not furnished) to seal the joints and all ductwork joints on both the inlet and outlet sides. Seal all joints for at least 3 ft. from cabinet.

FILTER PLACEMENT

1. Slide prefilters into shield channels and push all the way to the back of the cabinet.
2. Insert the electronic cells into the cabinet with THIS SIDE OUT label facing the door opening. Make certain the arrow stamped on the cell points downstream. See Fig. 6.
3. Close the door.

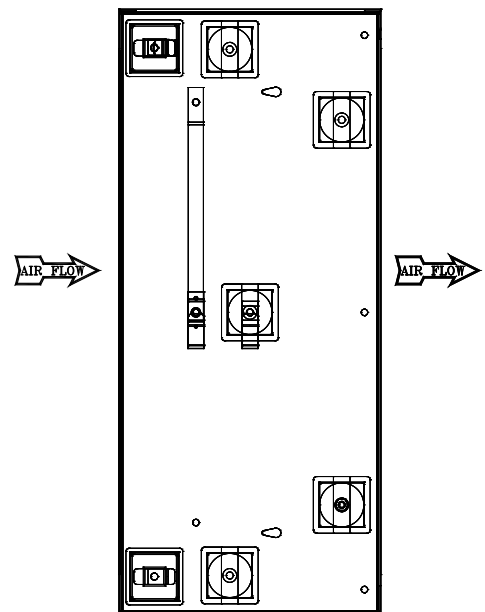

FIGURE 6 – CORRECT CELL ORIENTATION

PLUMBING INSTALLATION

Model	Recommended Min. Water Pressure during Wash		Recommended Hot Water Tank Size (Minimum)		Hot Water per Wash		Washes per unit of detergent		Recommended wash water temperature	Maximum water flow rate @ 30 psi (206.8 kPa)	
	psi	kPa	Gallon	Liter	Gallon	Liter	Gallon	Liter		Gal / min	Liter / min
AutoClean 2000	25	172.4	40	151.4	35	132.5	20	5.3	125 to 160 deg F (52 to 71 deg C)	4	15.1
AutoClean 4000	25	172.4	50	189.3	60	227.1	10	2.6		7	26.5
AutoClean 8000	25	172.4	100	378.5	112	423.9	6	1.6		14	53.0

FIGURE 7 – HOT WATER AND DETERGENT REQUIREMENTS

Connect the Hot Water Supply

Plumbing must comply with applicable codes and regulations. The hot water supply line from the heater to the air cleaner should be ¾" copper pipe.

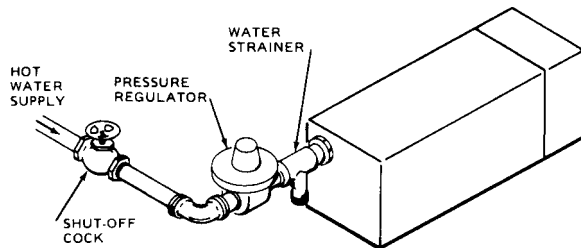

FIGURE 7 – TYPICAL INSTALLATION FOR HOT WATER SUPPLY

1. Install the water strainer (supplied) in the hot water line ahead of the water valve. See Fig. 8. The strainer protects the valves and washing jets from clogging.
2. Attach the pressure regulator valve (if water pressure is over 75 psi) to the water strainer.
3. Connect a faucet, if desired, for checking water temperature.
4. Connect backflow preventer if required by code.

Connect the Drain

Connect the drain spud (2 inch) in the base of the AutoClean cabinet to the waste drain. Use a water trap or check valve to prevent sewer odor

from entering the air cleaner base and spreading through the air system. Follow local codes. Test may have to be performed to check total water quality after air cleaner is installed.

Connect the Detergent Tank

1. Insert the plastic hose (supplied) over the plastic barb detergent pump connector.
2. Insert the hose into the tank. Make certain the metal tube rests on the bottom of the tank.
3. Close the top of the tank with the stopper provided to prevent debris from falling into the detergent.

NOTE: Multiple hoses can be inserted into a detergent tank. Maximum horizontal distance from the air cleaner to the detergent bottle is 20 ft., maximum vertical distance is 7 ft.

ELECTRICAL INSTALLATION

All wiring must comply with applicable local codes and ordinances. The power supply to the AutoClean air cleaner must be 120V or 240V, 60 Hz, or 220-240V, 50 Hz. Refer to the AutoClean nameplate for the proper voltage for your air cleaner.

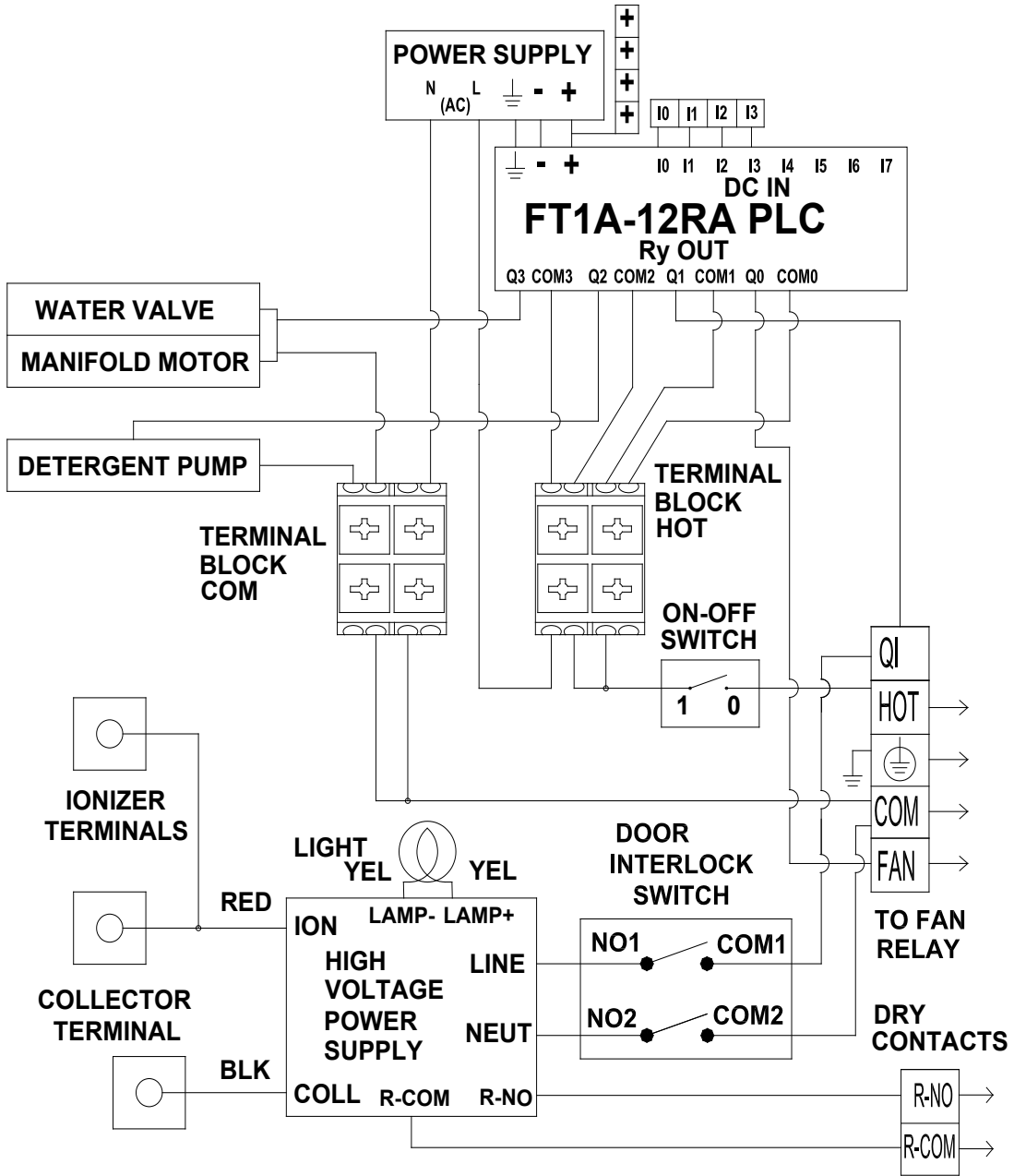

FIGURE 8 – INTERNAL WIRING SCHEMATIC FOR AUTOCLEAN 2000 AND 4000

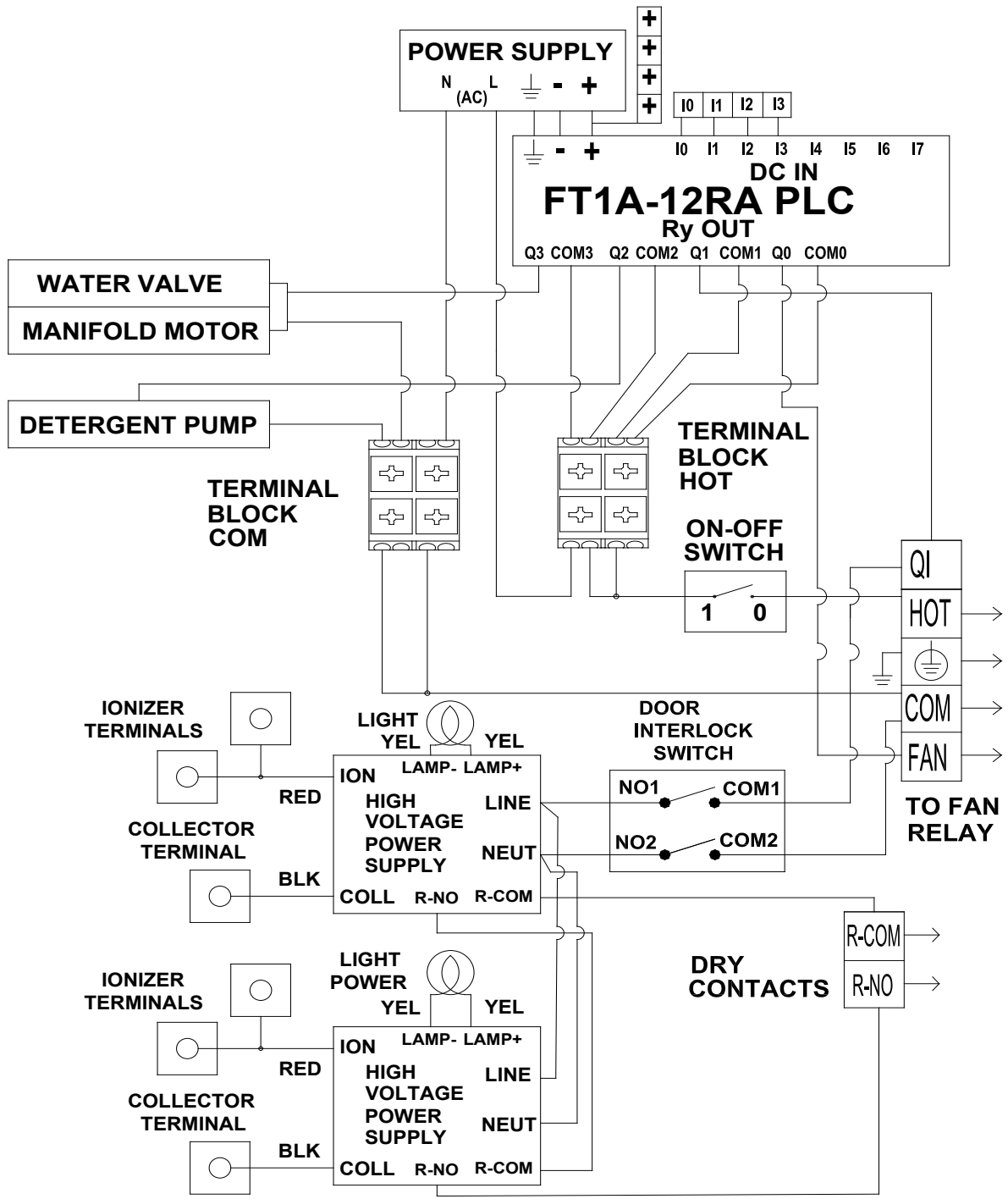

FIGURE 9 – INTERNAL WIRING SCHEMATIC FOR AUTOCLEAN 8000

CHECKOUT

- IMPORTANT -

Before putting the AutoClean Electronic Air Cleaner into service, check through the following items to be sure it is properly installed.

1. If outdoor air is used, care must be taken to prevent direct delivery of cold outside air across the electronic cell. Preheat the air in some manner or mix with return air.
2. Check over the installation for correct sheet-metal, plumbing and electrical work.
3. Turning vanes should be used in duct elbow to provide even air distribution across the cell.
4. When it is necessary to change the duct size close to the air cleaner, use gradual transitions to reduce turbulence.

GENERAL COMPONENT INSPECTION

1. Check for proper orientation of the electronic cells, protective screens and spray shield. Airflow arrows must point downstream. Impingers must be on both sides of the electronic cells.
2. Be sure that the electronic cells and impingers are clean, dry and free of foreign objects.
3. Be sure the spray manifold is located in the cabinet with nozzles pointed toward the cells.

CHECK THE JUNCTION BOX CONNECTIONS

Check all electrical connections to make certain they are correct and complete. Refer to the hookup diagrams (Figures 8 through 9).

CHECK THE PLUMBING CONNECTIONS

Check to be sure all plumbing work including the hot water supply and the drain are correct and will not leak!

CHECK THE ELECTRONIC CELLS AND THE POWER SUPPLY

With all components in place and the access door closed turn on the electronic air cleaner.

Check the indicator light on the power door. It should be on. With the power supply energized, momentarily open the access door. When the door opens the indicator light should go out.

If the power supply and electronic cells do not check out properly in this procedure, refer to the **TROUBLESHOOTING** section for additional checks.

CHECK THE AUTOMATIC WASHING CYCLE

The wash cycle for the electronic cell is controlled by the built in Programmable Logic Controller.

Initiate a wash cycle manually making sure the four cycles are running properly. When you get to the dry cycle it can take up to an hour for the cells to dry with the fan on.

The four cycles of the wash are:

1. Shutdown (Fan turns off and the high voltage power supply turns off)
2. Detergent (Water valve is open, Detergent pump and manifold motor are running)
3. Rinse (Water valve is open and manifold motor is running)
4. Dry (Fan is allowed to turn on)

Note: When the wash cycle is done the fan can be controlled as normal and the high voltage power supply turns on.

The manifold motor operates a cam and gear assembly to slowly move the manifold (water pipe and spray nozzles) during the wash cycle. Make sure there is complete coverage of the cells during a wash cycle.

MAINTENANCE

- CAUTION -

Always disconnect the power to the AutoClean before working on or near the air cleaner.

WHEN TO WASH THE ELECTRONIC CELLS

To maintain peak performance and efficiency, the electronic cells and spray shields in the electronic air cleaner must be washed regularly. This washing is necessary to remove the dirt particles accumulated during the air cleaning process. The cells and screens should be visually checked for dirt. Experience will probably be the best indicator of how often the cells and screens should be cleaned. For example, when operating in a thick smoke or particularly dirty atmosphere, the cells may need washing twice a week. If the dirt accumulation is light, the period between washings can be lengthened.

AUTOMATIC WASHING CYCLE

The cell wash cycle for the electronic air cleaner is controlled by a built-in Programmable Logic Controller. The washing assembly is operated by a motor.

Make sure that enough hot water is available for washing throughout the entire cycle. In installations with multiple electronic air cleaners, it may be necessary to stagger the timing of the wash cycles. This is to assure adequate water pressure and hot water for washing.

MANUALLY STARTING A WASH CYCLE

See instructions how to operate PLC at the end of this Owner's manual.

While the cells in the electronic air cleaner are being washed, a musty, dirty odor combined with the characteristic odor of the detergent may be noticed. This is caused when the accumulated dirt on the cells is washed off by the detergent and hot water spray. It will disappear after the washing is complete.

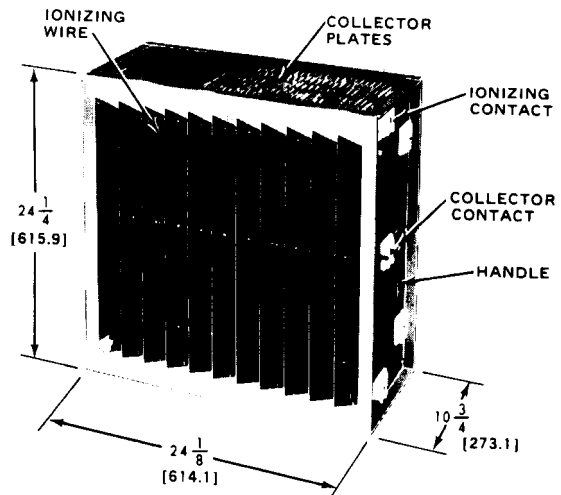

FIGURE 10 – PN 38010, ELECTRONIC CELL COMPONENTS. DIMENSIONS IN INCHES [MILLIMETERS SHOWN IN BRACKETS].

REPLENISH THE DETERGENT SUPPLY

- IMPORTANT -

Replenish the detergent supply in the tank before it is completely empty. If detergent is allowed to dry in the bottom of the hose or tank, the hose may become plugged.

NOTE: Maximum horizontal distance from the air cleaner to the detergent tank is 15 ft. [6.1 m]. Maximum vertical distance from the air cleaner to the tank is 7 ft. [3.0 m].

MANUALLY CLEANING

CLEANING THE IMPINGERS

The impingers in front of the electronic cells help stop the large particles. It's a good idea to check these impingers periodically to be sure they are not overloaded.

At intervals of about one year, the impingers should be removed to clean off the accumulated dirt. An overloaded impinger can restrict the airflow.



WASHING THE CELLS OUTSIDE THE ELECTRONIC AIR CLEANER

After routine washing, a noticeable buildup may remain on some parts of the cells. This is normal and has only a negligible effect on performance.

After a long period of service, perhaps every one to three years, the electronic cells should be removed from the cabinet and given an extra thorough washing. In many areas, professional cell cleaning services are available.

REMOVE THE CELLS AND THE IMPINGERS

1. Use care to avoid damage to the collector plates when handling and washing the cells.
2. Pull the handle to slide the cells out. Note the direction of the airflow arrows on the cells.
3. Pull the impinger out. Clean the dirt in the cell or impinger tracks.

MANUALLY CLEANING CELLS

Depending on the type of contaminant, different cleaners will be required. Smokemaster liquid detergent will be adequate to remove almost any type of dust, dirt, pollen and tobacco smoke. A cleaner, such as AQE's welding detergent part number 45026, will remove metal oxides such as those produced by welding. A cleaner, such as AQE's degreaser part number 45031, will remove greases associated with kitchen hoods.

- CAUTION -

Do *not* splash the cleaning solution in your eyes and avoid prolonged contact with your skin. Keep the detergent and solution out of the reach of children. Be sure to follow the cleaning solution label instructions for use or storage.

1. Mix the cleaning solution according to the label instructions.

2. Soak the cells for the time indicated on the cleaning solution label. Before removing the cells, slosh them around several times.
3. Rinse the cells with a fine spray.
4. Soak the cells and let the water drain. If the water draining from the cells feels slippery, they need more rinsing.
5. Inspect the cells for cleanliness. If any dirt remains, it probably indicates that the cells should be washed more frequently. Repeat this soaking procedure, as needed, to get the cells clean.

RETURN THE ELECTRONIC CELLS AND THE IMPINGERS TO THE UNIT

1. Place the electronic cell so that the arrow on the handle-side of the cell points in the direction of the airflow.
2. Insert the impingers in the channels provided.
3. Close the power door.

IONIZING WIRE REPLACEMENT

The fine wire electrodes in the charging section of the electronic cell may break or become damaged. During operation, a broken or deformed wire generally causes a short to ground, possibly with visible arcing or sparking. This condition, or any other short in the charging section, is indicated by the status light on the power door. Broken wires must be replaced. Remove all parts of the broken wire and temporarily use the cell short of one wire until it can be replaced as directed below. To replace the ionizing wires, remove the electronic cell from the cabinet and proceed as follows:

1. Remove all of the broken wire from the cell mounting brackets. See Fig. 11.
2. Install the new wire.

Insert the crimped end of the ionizing wire into the keyhole then hook the spring end into the mounting bracket hole.

Use a long nose pliers and carefully pull the spring until the hooked end can be secured in the mounting bracket hole.

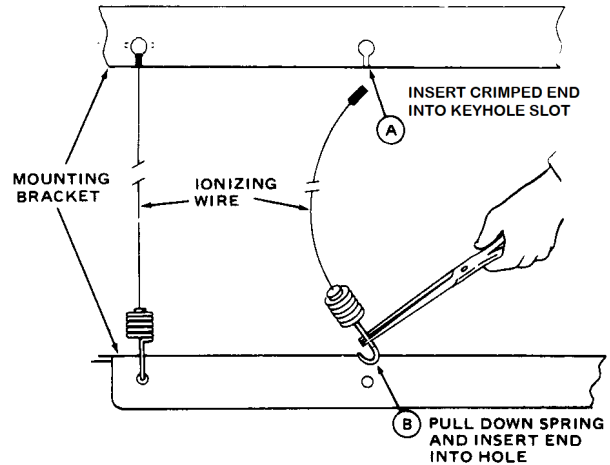

FIGURE 11 – METHOD OF REPLACING THE IONIZING WIRE

TROUBLESHOOTING

WARNING!

The following instructions are intended for qualified service personnel only. Dangerous line voltage circuits are exposed during this procedure. Disconnect the power before servicing the unit. Voltage may exceed 12,000 VDC. Make sure meter to be used has appropriate voltage rating.

Before beginning this section make sure to review the checkout and maintenance sections!

Make sure all wiring is connected properly reference figures 8 and 9.

FIGURE 12 - CONTROL BOX COMPONENTS

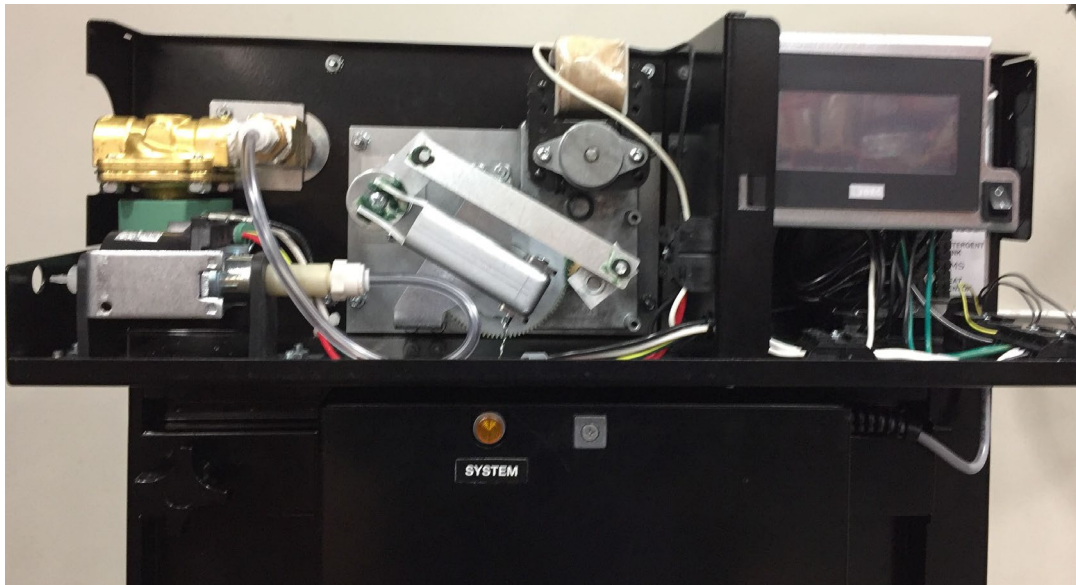

Indicator light flickers / Unit makes zapping noises

Some flicker is inherent in neon indicator lights and is not an indication that anything is wrong. If the indicator light blinks off and back on and is accompanied by a clicking or zapping noise that is frequent, it is an indication that the electronic collector cell(s) may be dirty or damaged. A wash cycle should be performed to clean the cell. An occasional blink or snapping is normal.

If the wash cycle does not eliminate the noise remove the cells and investigate them looking for bent collector fins or a large particle stuck in a cell. Also check the contacts on the cells and inside the unit for a possible bad connection.

Remove any particles taking care not to bend the collector plates or break any ionizing wires.

Replace any missing or broken ionizing wires, reference the parts list for replacement.

If a collector plate is bent causing the arcing (bug zapper noise), one may attempt to bend the plate back to an original position with a duckbilled pliers. Care must be used as further damage can be caused by stretching the aluminum plates, which can render the cell unrepairable. Please contact Air Quality Engineering at 1-800-328-0787 for assistance.

Indicator light is NOT on

Check to see if the wash system is operating. The indicator light should not be lit when the wash system is activated.

Check to see if the cell access door is closed properly. The indicator light will not be lit if the door is open and the electronic cells will not be energized.

Be sure the electrical connections have been made properly per Figure 8 & 9.

Remove the electronic collector cell(s) and close the door. If the light comes back on, there is a short in at least one collector cell. A short can be a result of the cell(s) being excessively dirty, a large piece of contaminant shorting the fins, or a physical damage such as a collector fin being bent out of shape and touching an adjoining fin. The wash cycle may be run to clean the cells if they appear dirty. Visually inspect the cell for large particulate that may be bridging two adjoining collector fins or for physical damage. If damage is identified, repairs should only be performed by trained personnel as improper repairs may result in unrepairable damage. Please contact Air Quality Engineering, Inc. at 1-800-328-0787 for assistance.

If the indicator light does not come on with the cells removed and the door closed, use a voltmeter to confirm that there is indeed voltage at the input of the power supply. If there is voltage at the power supply, but no indicator light, the power supply should be replaced. The indicator light itself has a very low failure rate.

Water not Flowing

Check to make sure the water valve is getting energized. One should hear a clicking from the solenoid when the PLC engages and disengages the solenoid. If this is not occurring one could check this by manually taking apart the hot water solenoid or a new assembly might have to be installed.

Detergent not Flowing

During the detergent cycle the detergent pump should energize and pump from the tank and dispense from the manifold jets with the water. If the detergent is not being dispensed check for the following: If the detergent supply tank is empty. If the detergent supply tube is restricted. If the detergent pump is running. The detergent pump makes a significant amount of noise and should be audible while it is running.

If the pump is not running, check to make sure it is receiving voltage, If it does, but pump does not run, the pump may need to be replaced.

Too much detergent being used

The length of time the detergent pump is on during the wash cycle can be adjusted in PLC settings.

Mechanical wash system not working (the nozzles are not turning or not traversing along the cells, during the wash and rinse cycle.)

The manifold motor operates both the rotation and traversing motion of the jets. Check to see if the manifold motor is operating.

If the motor is still not operational check to see if it is getting voltage.

If no voltage is getting to the motor trace wiring back and find the break.

If voltage is getting to the motor and still no movement is coming from the motor the motor will need to be replaced. Reference the parts list for replacement.

Make sure that the linkage is not being stopped by an obstruction.

PLC INSTRUCTIONS

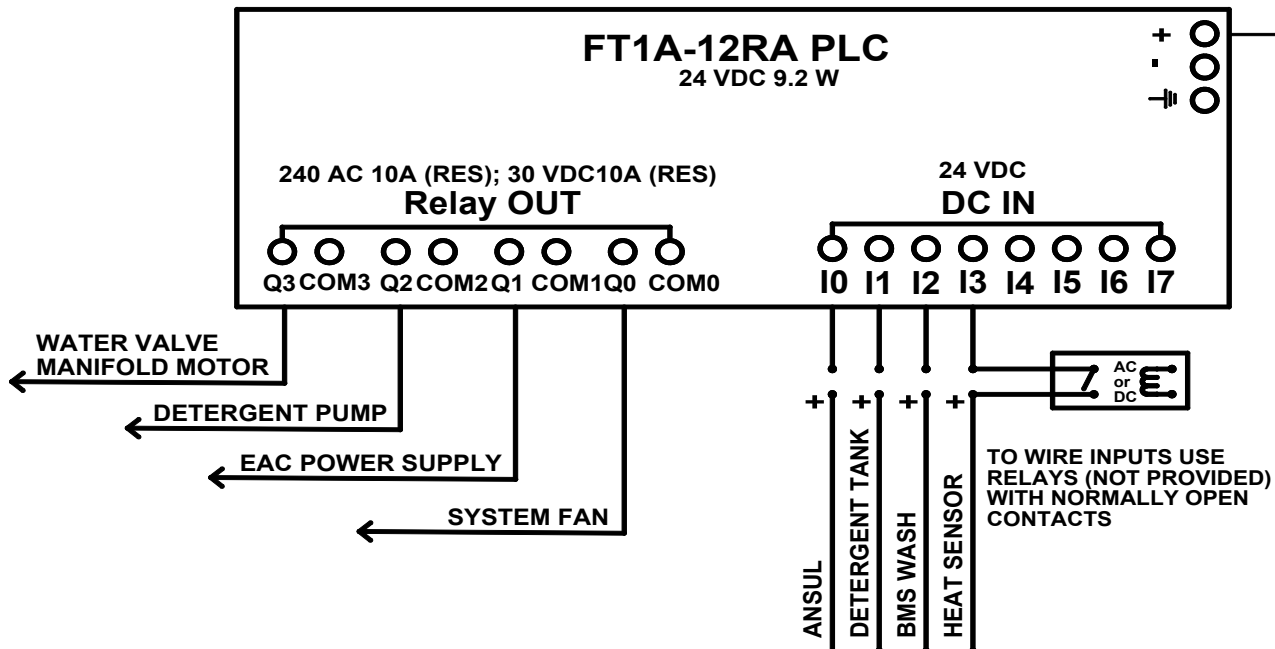

Inputs:

- 1. Heat Sensor** - It could be installed in the kitchen and works as the trigger to power on the system fan and EAC.
- 2. BMS wash** – Controls wash cycle from Building Management system.
- 3. Detergent tank sensor.** There is flashing warning about empty tank.
- 4. Ansul control.** Turns fan on and everything else off.

Home screen

Present unit mode

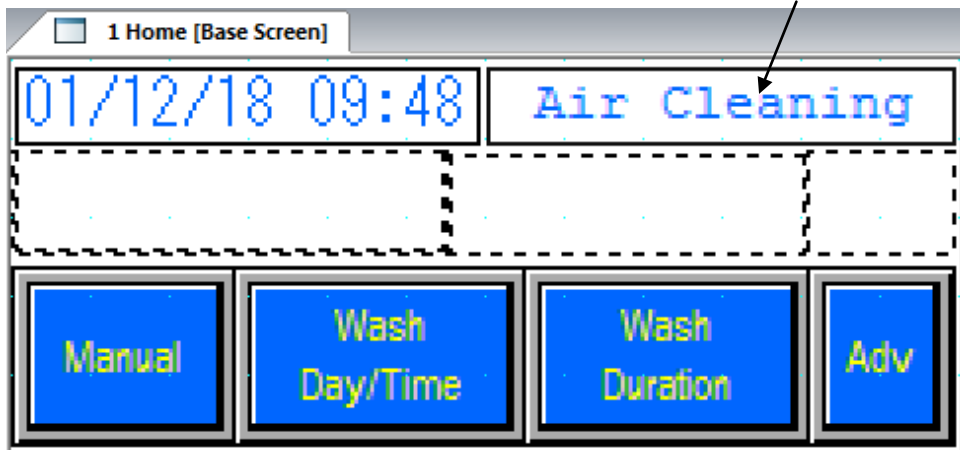

Touch “Manual” button to start wash manually.

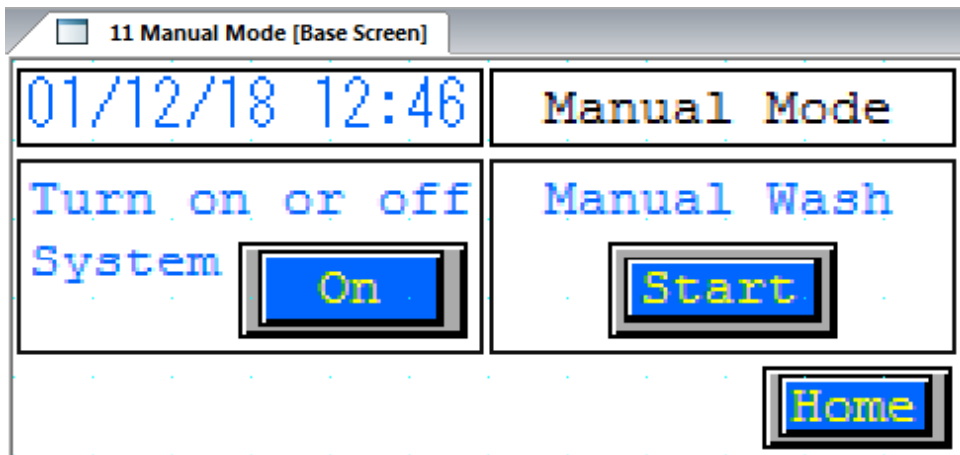

Touch “Start” button to start manual wash.

You will get “Ready to wash?” message.

Touch “Ready” button to start.

To change duration of “Rinse” cycle for example touch “Wash duration” button in Home screen.

You will get this screen

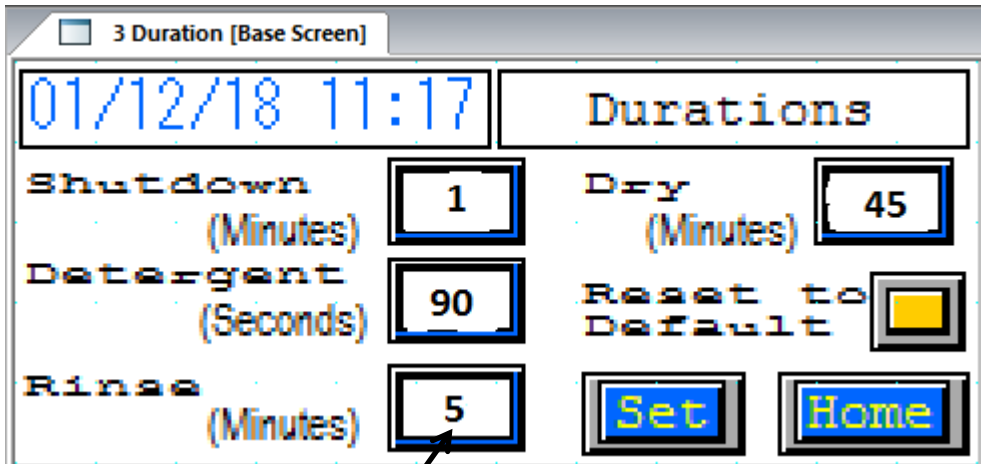

Touch this button to change the amount of time it will rinse. The maximum number is 120 minutes.

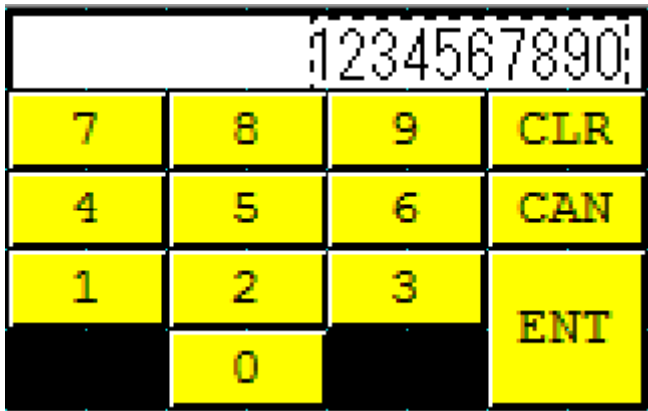

Enter the number and touch ENT

To program wash on the day of week
touch “Wash day/time” button in Home screen.
You will get this screen

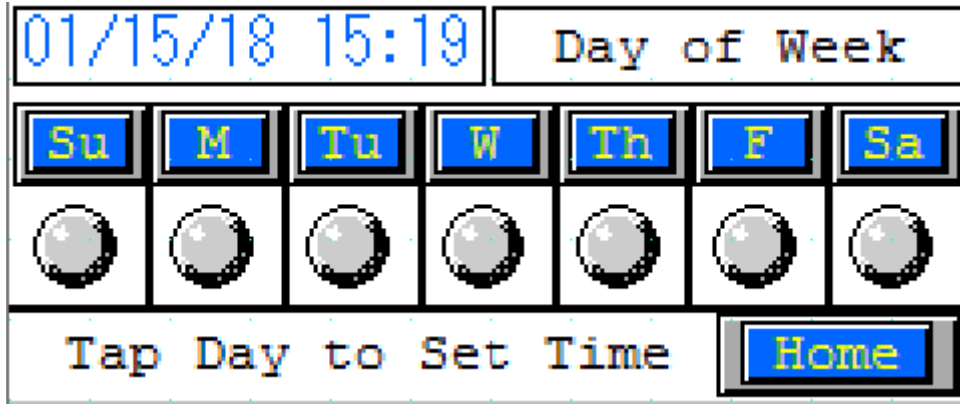

Touch the blue rectangle button for the day of the week you want.

You will get this screen

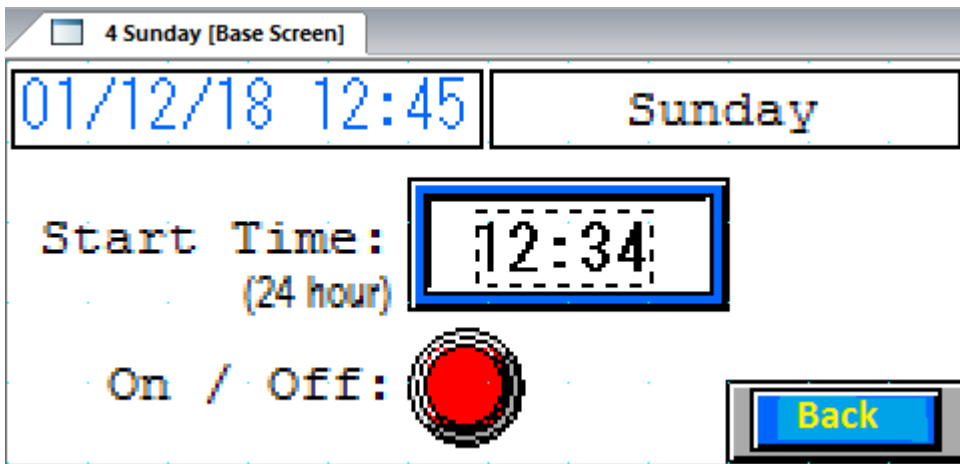

Enter time on 24 hour scale, touch On/Off button.
It becomes green for ON.

“Adv” button on home screen will bring this menu.

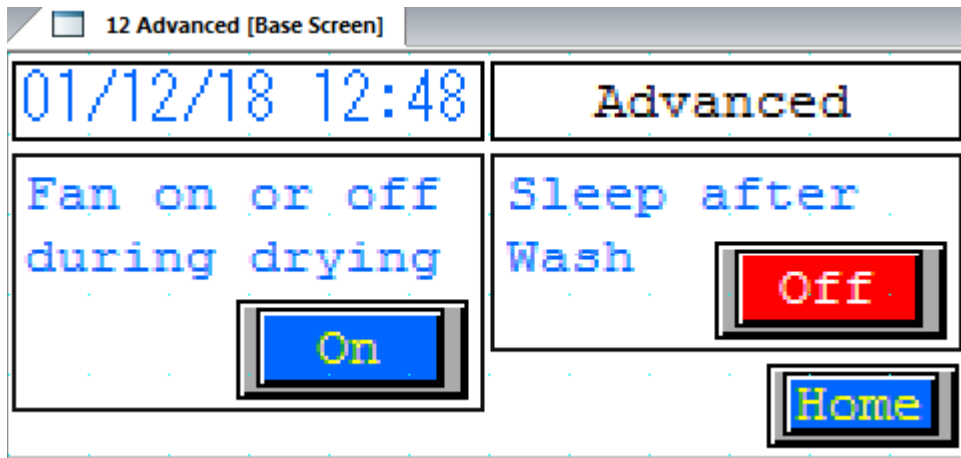

You have two independent advanced options:

- 3. You can have fan “on” or “off” during drying.**
- 4. The unit can go to “sleep” mode after wash. You have “Resume air cleaning” button during the sleep.**

CERTIFICATE OF WARRANTY

ONE-YEAR LIMITED WARRANTY

Air Quality Engineering, Inc. (AQE), warrants to the original purchaser, subject to the conditions below, that if the "Product" covered by this warranty should fail to perform by reason of improper workmanship or material, AQE will during the period of one (1) year from the date of original purchase either (i) replace the product or (ii) provide all necessary parts to repair the product without charge. The decision to replace the product or the necessary parts shall rest solely with AQE. This one-year limited warranty does not apply to main filter elements. AQE will replace without charge the main filter elements during the period of thirty (30) days from the date of original purchase if the main filter elements fail to perform by reason of improper workmanship or material. This warranty is valid only under the following conditions:

CONDITIONS

1. **REGISTRATION:** The purchaser's completion and mailing of the Registration Card to Air Quality Engineering, Inc., 7140 Northland Drive North, Minneapolis, Minnesota 55428-1520 within 30 days of original purchase.
2. **AUTHORIZATION:** The purchaser will contact AQE at (763) 531-9823 for authorization, returned goods number (RGA) and the shipping address. AQE will direct the purchaser to either return the necessary parts or the product at AQE's option.
3. **PROPER DELIVERY:** The shipping, freight prepaid or delivery of the parts or the product to AQE in either its original carton or in a carton assuring similar protection of the product with the returned goods number (RGA) clearly displayed on the outside of the carton.
4. **UNAUTHORIZED REPAIR:** A showing by the original purchaser that the product has not been altered, repaired or serviced by anyone other than an authorized service technician using genuine AQE parts.
5. **UNAUTHORIZED PARTS:** A showing by the original purchaser that the product has had only genuine AQE parts and filters used in its operation and maintenance.
6. **SERIAL NUMBER INTACT:** A showing by the original purchaser that the serial number has not been altered or removed.
7. **MISUSE:** A showing by the original purchaser that the product has not been involved in an accident, freight damaged, misused, abused or operated contrary to the instructions contained in the Owner's Manual.

Air Quality Engineering, Inc.'s, sole responsibility shall be to repair or replace the product within the terms stated above. AQE SHALL NOT BE LIABLE FOR ANY CONSEQUENTIAL DAMAGES RESULTING FROM ANY BREACH OF WARRANTY, EXPRESS OR IMPLIED, APPLICABLE TO THIS PRODUCT. Some states do not allow the exclusion or limitation of consequential damages so this limitation may not apply to you.

THIS WARRANTY IS IN LIEU OF ALL OTHER WARRANTIES, EXPRESS OR IMPLIED, AND THE WARRANTIES OF MERCHANTABILITY AND FITNESS FOR A PARTICULAR PURPOSE ARE HEREBY EXCLUDED BEYOND THE ONE-YEAR DURATION OF THIS WARRANTY. Some states do not allow limitations on how long an implied warranty lasts so the above limitation may not apply to you.

This warranty gives you specific legal rights and you may also have other rights that vary from state to state.

**AIR QUALITY ENGINEERING, INC.
7140 NORTHLAND DRIVE NORTH
MINNEAPOLIS, MINNESOTA 55428-1520**

**TOLL FREE: 1-800-328-0787
TELEPHONE: (763) 531-9823
FAX: (763) 531-9900**

MANUFACTURER & WORLDWIDE DISTRIBUTOR OF SMOKEMASTER® AIR CLEANING SYSTEMS

Printed in the USA